



H-20 Fuel Cell Stack



User Manual

Updated 13 Dec. 2011

Disclaimer

This manual incorporates safety guidelines and recommendations. However, it is not intended to cover all situations. It is the responsibility of the customer to meet all local safety requirements and to ensure safety during operation, maintenance and storage of the H-20 stack.

Although all efforts have been made to ensure the accuracy and completeness of the information contained in this document, Horizon reserves the right to change the information at any time and assumes no liability for its accuracy.

Actions that will void the fuel cell and controller warranty:

- Attempt, under any circumstance, to disassemble or inappropriately tamper with the fuel cell.
- Operate the fuel cell with a controller not designed and built by Horizon for the specific fuel cell.
- Operate the fuel cell with valves and blowers that are not provided by Horizon for the specified fuel cell and controller.
- Disassemble the fuel cell.
- Disassemble the controller.
- Operate the fuel cell stack and controller that is not in the setup and/or specified in the user manual provide for the specific product.
- Operate the fuel cell stack without the controller produced by Horizon or with the controller not produced by Horizon.

Do not attempt, under any circumstance, to disassemble or inappropriately tamper with the fuel cell. There will be no returns, refunds or exchanges should disassembly or tampering occur. If you have questions or need help with regards to the fuel cell and its technology contact - support@horizonfuelcell.com.

IMPORTANT

In order for the warranty to come into effect the stack must be registered on the Horizon Warranty Page at: www.horizonfuelcell.com/warranty.htm

Table of Contents

1. Safety	4
2. Terminology	9
3. Stack and System Component Information	10
4. Technical Specification	11
5. System Performance Curves	12
6. System Set-Up	13
6.1 Operating instructions	13
6.2 Simplified Drawings of HFCT Measurement Stand.....	15
7. Storage and Re-Use	16
8. Trouble Shooting	17

1. Safety

Please read all instructions carefully prior to product use and keep this manual for future reference.

The safety guidelines included here may not cover every situation. Use common sense.

1.1 General information

For this unit to generate electrical power, a supply of hydrogen fuel is necessary. It is important for any operator to be aware of, understand, and follow all local safety requirements related to the handling of hydrogen and compressed gases. Ensure that your facility conforms to all local regulatory requirements, including building codes and recommendations.

The fuel cell system has built-in safeguards and is designed to shut down automatically if any out-of-range operating condition occurs. Possible situations include low cell voltage, high current, high temperature, low fuel pressure.

- Do not operate the stack on a grade of more than 65°C.
- Do not connect or disconnect power cables when the fuel cell stack is energised.
- Do not dismantle the system. Contact Horizon if you have any concerns about operation.

1.2 Using Hydrogen

WARNING! FIRE OR EXPLOSION

Keep all sources of ignition away from hydrogen.

This unit uses hydrogen fuel. Hydrogen is a colourless, odourless and flammable substance. It is highly combustible in the presence of oxygen and burns with a colourless flame.

Leaking gas may be hot and pose a burn danger. Stop the flow of gas – if you are not in danger – and use water to cool the area. If fire occurs, do not attempt to extinguish flames, allow the fire to burn out.

Prevent overexposure to hydrogen. Hydrogen is non-toxic but can act as a simple asphyxiant by displacing the oxygen in the air. There are no warnings before unconsciousness results. When operating the stack in an enclosure:

- Ensure ventilation slots are clear and unobstructed at all times during operation.
- Operate within the temperatures limits stated in the manual.
- Never operate if an alarm condition exists.

Note: We highly recommend customer use a hydrogen sensor(not provided) to detect the hydrogen leakage.

1.3 Handling Compressed Gas Cylinders

WARNING

Do not handle compressed hydrogen gas cylinders without training or experience.

- Use a pressure regulator to control the fuel inlet pressure to the system.
- Do not alter the fitting on a regulator. Ask experienced personnel for help.
- Do not attempt to force gas cylinder threads.
- Never transport a gas cylinder with regulators attached. Ensure cylinder caps are in place. Always use a cylinder cart with a safety strap or chain.
- Secure a high-pressure cylinder to a bench, post, or fixed object to avoid accidental contact.
- Avoid unnecessary contact with On/Off valves. They can easily move to “On” by accident.

1.4 Hydrogen Leakage

Hydrogen is colourless, odourless and tasteless. Hydrogen is non-toxic but can act as a simple asphyxiant by displacing the oxygen in the air. There are no warning symptoms before unconsciousness results.

WARNING

Inhaling hydrogen can lead to unconsciousness and asphyxiation. Hydrogen molecules are smaller than any other gas, making hydrogen more difficult to contain. It can diffuse through many materials considered airtight. Fuel lines, non-welded connections, and non-metal seals such as gaskets, O-rings, pipe thread compounds and packings present potential leakage or permeation sites. Furthermore, hydrogen's small molecule size results in high buoyancy and diffusivity, so leaked hydrogen will rise and become diluted quickly.

Constant exposure to hydrogen causes hydrogen embrittlement in many materials. The mechanisms that cause hydrogen embrittlement effects are not well defined. Factors known to influence the rate and severity of hydrogen embrittlement include hydrogen concentration, hydrogen pressure, temperature, hydrogen purity, type of impurity, stress level, stress rate, metal composition, metal tensile strength, grain size, microstructure and heat treatment history. Moisture content in the hydrogen gas may lead to metal embrittlement through the acceleration of the formation of fatigue cracks. Hydrogen embrittlement can lead to leakage or catastrophic failures in metal and non-metallic components.

As a preventative measure, the stack must be operated in a well-ventilated area in order to inhibit potential hydrogen accumulation.

WARNING!

Always operate the stack in a well-ventilated area and ensure that ventilation slots are unobstructed.

1.5 Flammability and volatility

Hydrogen is flammable over concentrations of 4 – 75% by volume in air, and is explosive over concentrations of 15 – 59%. As a result, even small leaks of hydrogen have the potential to burn or explode. Leaked hydrogen can concentrate in an enclosed environment, thereby increasing the risk of combustion and explosion.

Hydrogen flames are pale blue and are almost invisible in daylight due to the absence of soot. Due to its high buoyancy and diffusivity, burning hydrogen rises unlike gasoline, which spreads laterally.

A flammable or explosive hydrogen mixture is easily ignited by a spark or even a hot surface. The auto-ignition temperature of hydrogen is 500 °C (932 °F). The energy of a hydrogen gas explosion is 2.4 times that of gasoline or methane for an equal volume. Hydrogen gas explosions are therefore more destructive and carry further.

WARNING!

A mixture of hydrogen and air is potentially flammable and explosive and can be ignited by a spark or a hot surface.

As in the presence of any fuel, all sources of ignition, including smoking, are not permitted in the vicinity of the stack.

WARNING!

Keep all sources of ignition away. Smoking is not permitted in the vicinity of the stack.

1.6 Oxygen Depletion

Oxygen is a colourless, odourless, non-toxic and tasteless gas. Oxygen is essential for life in appropriate concentrations.

Ambient air contains up to 21% oxygen. Oxygen levels below 19.5% are biologically inactive and may act as simple asphyxiants. Effects of oxygen deficiency may include: rapid breathing, diminished mental alertness, impaired muscular coordination, faulty judgement, depression of all sensations, emotional instability, and fatigue. As asphyxiation progresses, nausea, vomiting, prostration, and loss of consciousness may result, eventually leading to convulsions, coma, and death. At concentrations below 12%, immediate unconsciousness may occur with no prior warning symptoms.

WARNING!

Lack of oxygen can lead to unconsciousness and asphyxiation.

As a preventative measure, the stack must be operated in a well-ventilated area in order to compensate for the oxygen used within the fuel cells.

WARNING!

Always operate the stack in a well-ventilated area.

1.7 Electrical Safety

WARNING!

Avoid contact with an exposed fuel cell stack. Electrical shock can cause personal injury or death.

- Do not touch fuel cell plates or any electrical components at any time. A running fuel cell stack is a potential electrical hazard that can cause burns or electrical shock.
- Do not wear metallic jewellery – rings, bracelets, watchbands, or necklaces – when you are close to an exposed fuel cell stack.
- Minimise static discharge. If possible, ground all equipment.
- Minimise conductivity. Avoid contact with surfaces that are in contact with water or gases. Do not operate or store in wet or damp conditions.
- Never use damaged extension cords.

The stack generates up to 13 VDC (open circuit voltage). This voltage decreases as current is drawn from the stack. The stack produces 7.8V at maximum power. This voltage is exposed at the output power connections. These low voltages may constitute a shock hazard and can damage electronic components if shorted. Therefore, do not touch individual fuel cells, cell voltage monitoring equipment or electrical components.

WARNING!

Do not touch fuel cells, cell voltage monitoring equipment or electrical components. Electronic components can also be damaged as the result of static discharge. To minimise this, ground all equipment in contact with the stack. Never use damaged extension cords. Minimise conductivity by avoiding surfaces in contact with water; hands and clothes must be dry. Do not operate or store the stack in wet or damp conditions.

WARNING!

Minimise static discharge. Ground all equipment. Residual reactants within the stack can develop a charge in a matter of minutes when turned off. A reading of zero volts across the entire stack does not guarantee that all fuel cells are uncharged.

WARNING!

Always assume that the fuel cell stack is charged. Jewellery (such as rings, necklaces, bracelets and watches) may concentrate an electric current when it comes into contact with charged components, or when a shock passes through the human body. Accordingly, no jewellery should be worn near the stack.

WARNING!

Do not wear jewellery near the stack.
No pungent odor, paint and perfume are allowed around stack.

1.8 High Temperature

The fuel cell stack is designed to operate at 65°C. At this operating temperature, the air exhaust stream temperature can reach 55°C and the cooling air stream can reach 17°C above ambient conditions. These temperatures are sufficient to cause burns or severe discomfort. Accordingly, avoid contact with the fuel cell stack, or components that convey process or cooling air.

WARNING!

Avoid contact with the fuel cell stack or components that convey process or cooling air.

2. Terminology

PEM fuel cell: a PEM (Proton Exchange Membrane) fuel cell is a device that converts Hydrogen and oxygen into water and electricity.

Reactants: reactant is a material used to start a chemical reaction. In the fuel cell the reactants are air and Hydrogen by which the electricity will be generated.

Humidification: humidity that the fuel cells need for running.

Blower: supply air to the fuel cells and meanwhile decrease the temperature in the stack.

Mass flow per minute: the total amount of the Hydrogen flow to the fuel cell every minute, which the Hydrogen supply can be calculated.

HFCT: Horizon Fuel Cell Technologies

3. Stack and System Component Information



1. Stack

It includes a plurality of plate-like fuel cells arranged along an axis generally parallel to cell thickness with electrically conductive separator plates between each pair of cells.



2. Tube

It is used for connecting the pressure regulator to the stack, the stack to the purge valve and the purge valve to a place away from the stack.



3. Controller

It controls the purging and short circuiting of the stack.



4. Purge valve

It controls the purging time for purging water and redundant Hydrogen from the fuel cells.

4. Technical Specification

Type of fuel cell	PEM
Number of cells	13
Rated Power	20W
Performance	7.8V @ 2.6A
Purging valve voltage	6V
Blower voltage	5V
Reactants	Hydrogen and Air
External temperature	5 to 30°C
Max stack temperature	55°C
H2 Pressure	0.45-0.55bar
Hydrogen purity	≧ 99.995 % dry H2
Humidification	self-humidified
Cooling	Air (integrated cooling fan)
Weight (with fan & casing)	275 grams(±30 grams)
Controller	90 grams(±10 grams)
Dimension	7.5cmX4.7cmX7.0cm
Flow rate at max output*	0.28 L/min
Start up time	≦ 30S at ambient temperature
Efficiency of stack	40% @ at full power

*The flow rate may change with the power output

** The Specification is subject to change without notice.

5. System Power Curves

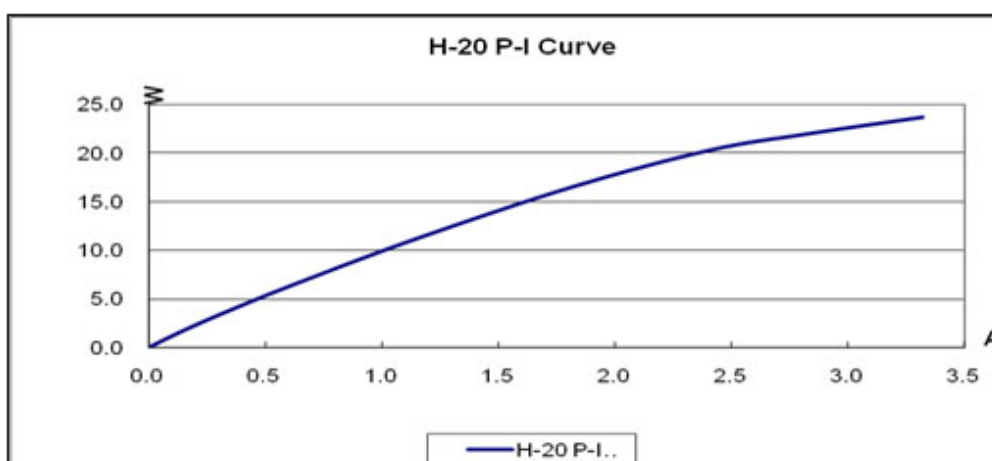
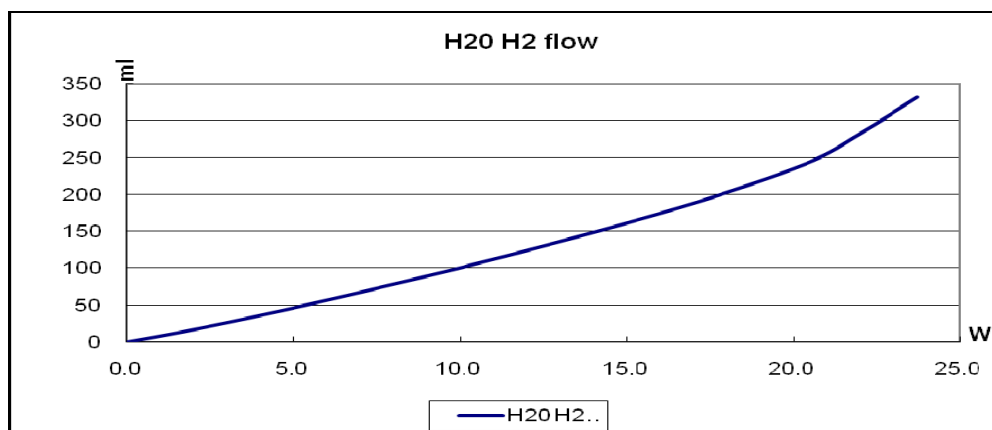
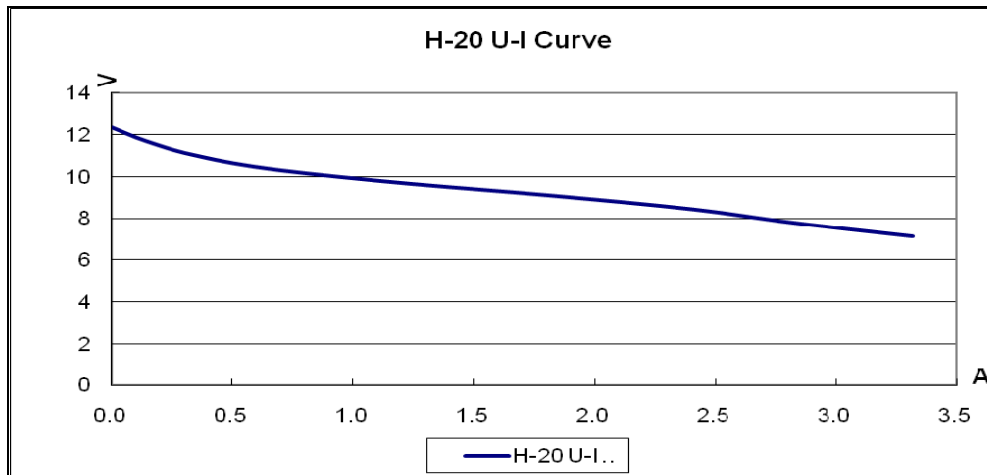

6. System Set-Up

6.1 Operating Instructions

PLEASE READ CAREFULLY BEFORE STARTING

WARNINGS:

1. The tube between the hydrogen pressure regulator and the fuel cell gas input is required to be less than 30cm. The inner diameter of the hydrogen supply tube is required to be more than 2mm. The input pressure to the stack is required to be 0.45-0.55Bar.
2. Disconnect the hydrogen tube from the hydrogen input immediately after the fuel cell stack is shut down. Since hydrogen gas can leak into the fuel cell and destroy the stack.
3. Make sure the dry Hydrogen gas to be used must be $\geq 99.995\%$ purity.
4. Do not vibrate the stack when it is in operation.
5. Keep the stack in ventilation when it is in operation.
6. The tube between stack output and purging valve is required to be less than 20cm. The tube connected to the purging valve output is required to be less than 30cm. The inner diameter of the tube is required to be more than 2mm.

Step 1: Use the tube to connect the Hydrogen (0.45-0.55 Bar) to the fuel cell hydrogen input port. Connect the controller to the fuel cell and also connect the controller to the purging valve.

Note: The white plastic point of the purging valve is for input and the metal point for output.

Warning: The tube between the hydrogen pressure regulator and the fuel cell gas input is required to be less than 30cm.

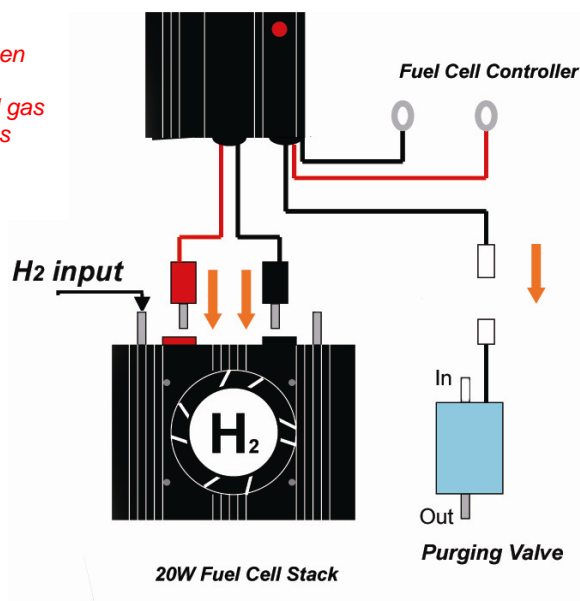

Step 2: After the low pressure hydrogen (0.45-0.55 Bar) is supplied to the fuel cell, the fan/blower should start to operate. The hydrogen shall flow through the stack. The red light on the controller should be on for a short time and then it will go off. Connect a tube to the purging valve input.

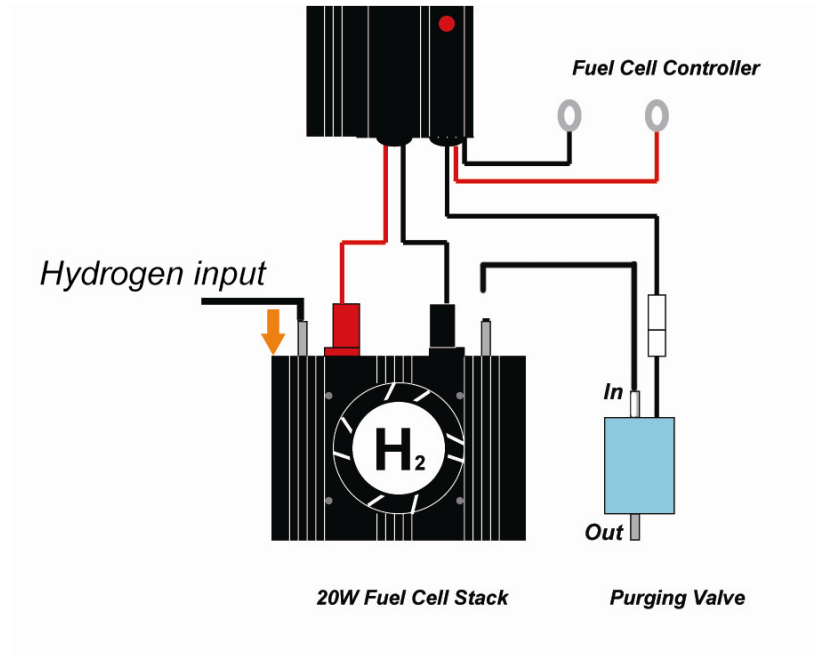

Step 3: To obtain higher efficiency and better water management, please connect the other end of the tube from the purging valve to the hydrogen outlet port.

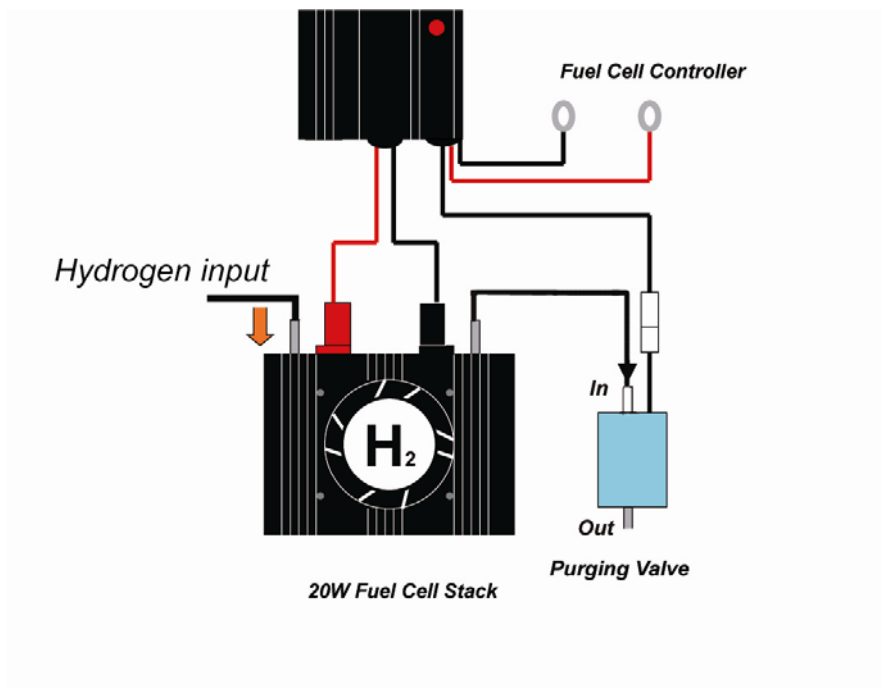

Step 4: The fuel cell system is now ready for use. Please connect the load to the fuel cell system.

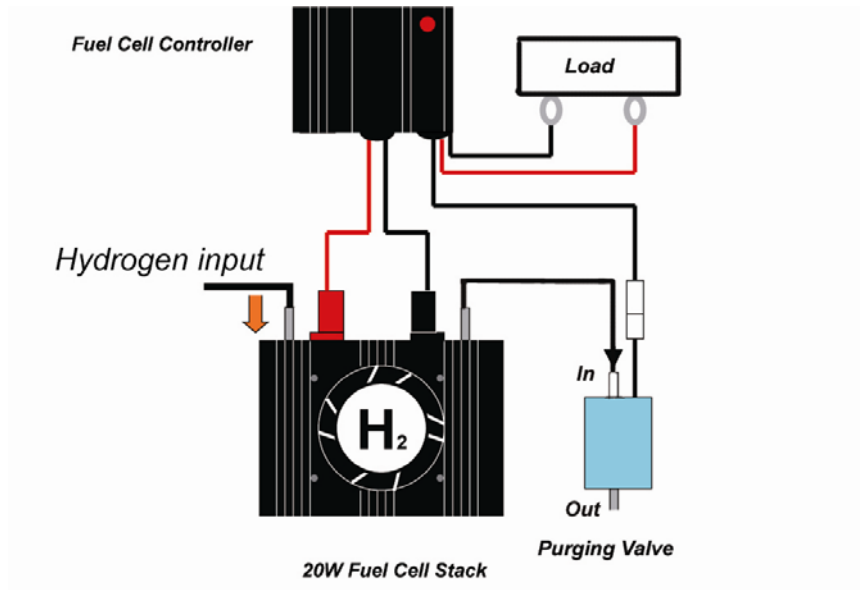

WARNING: Disconnect the hydrogen tube from the hydrogen input immediately after the fuel cell stack is shut down. Since hydrogen gas can leak into the fuel cell and destroy the stack.

6.2 Simplified Drawings of HFCT Measurement Stand

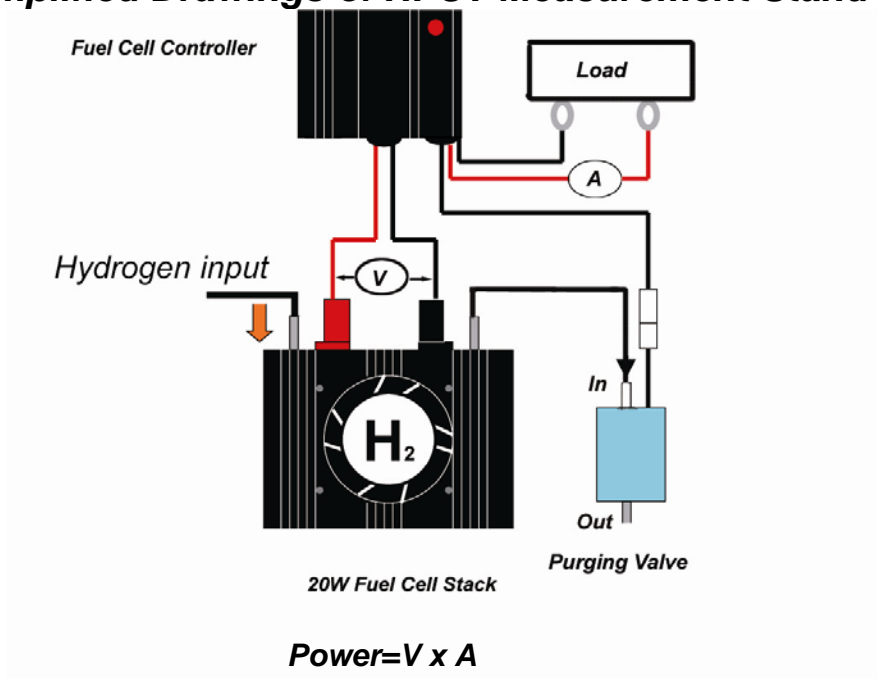

7. Storage and Re-Use

When finished operating the stack, place it back in the air tight container and keep it in an enclosed area for storage to keep the stack from getting too dry. The stack should be stored at room temperature.

If the stack is un-used for a long period of time (more than 4 weeks) and the performance goes down 50% to the rated power at 7.8V after 30 minutes operation we recommend do the following steps.

Note: Generally, injecting water into the stack it is not recommended. Only if the performance of the stack decreases 50% is it recommended to inject water into the stack to activate the stack before operation.

Rejuvenate by injecting water into the stack:

1. Connect a short section of hosing to the hydrogen input port on the stack.
2. Fill a syringe with water (distilled or purified). Make sure there is no air in the syringe. And then connect it to the hose attached to the stack.
3. Inject distilled or purified water into the stack until you see water coming out of another port (see picture A below for reference). Keep the water inside the stack for about 2 minutes. Now disconnect the syringe with the tube, and leave the water in the stack.
4. Purge the water out of the stack as much as much before use, say, it is not coming out of the stack output. Connect a tube to the hydrogen output port. Set the H₂ supply to 0.45-0.55Bar and connect it to the hydrogen input port of the stack without a load attached, and purge the stack as much as possible (i.e. letting hydrogen flow through the stack to remove water and other contaminants). Please see picture B below for reference. Using a fuel cell stack with too much water inside can irreparably damage it!

Make sure the hydrogen supply pressure is 0.45-0.55Bar.



A



B

WARNING:

Make sure you have purged the water out of the stack as much as possible before use. Using the fuel cell stack with too much water inside can irreparably damage it!

8. Trouble Shooting

1. Make sure the dry Hydrogen gas to be used must be $\geq 99.995\%$ purity.
2. The tube between the hydrogen pressure regulator and the fuel cell gas input is required to be less than 30cm.
3. The inner diameter of the hydrogen supply tube is required to be more than 2mm.
4. The input pressure to the stack is required to be 0.45-0.55Bar.

If the system shuts down by itself check the following details:

1. Make sure you have connected all wires according to the diagram on page 15.
2. Make sure you have a hydrogen input supply at 0.45-0.55Bar to the stack.
3. Make sure the load is below 20W, because the controller will protect the stack from drawing too much current.

The blower does not run after the stack was connected according to the System set up and hydrogen was supplied.

Contact Horizon Fuel Cell Technologies for support.

The open voltage (no load stack voltage) is less than 9.1V.

1. Inject water into the stack (**see Storage and re-use for details**). And then re-test open voltage.
Note: Make sure you have purged the water out of the stack as much as before use.
2. Connect a load 5-6W to the stack. And then note the voltage and current to check if they comply with our power curve. If not, inject water (**see Storage and re-use for details**) and run the stack again.
3. If the voltage and current from the 5-6W load comply with the power curve, increase the load till 20W. If the voltage and current from the high power load does not comply with the power curve, check the hydrogen pressure to the stack and the flow rate. Meanwhile purge the stack and then observe the stack.
4. Run the stack at 7.8V for 30minutes, while its performance does not go up. Contact Horizon Fuel Cell Technologies for support.

The light on the controller keeps on flashing red.

Reduce the demand of the load on the fuel cell stack.